



Aluminium
SLIDING & BI-FOLD DOOR SYSTEMS

Bi-Fold 26Hi / 26Hi+ Systems

High Performance Thermally Enhanced Bi-Folding Door

At Carroll's Glass our thermal range of Bi-Folding doors are the perfect solution to open up your home and bring the outside in, while keeping the elements out. Our Bi-Fold doors offer a wide range of designs from two to seven panes and up to 6 metres in width giving architects, clients and specifiers total design flexibility. The door can also be used in a single door application. Door sashes can accommodate either open in or open out applications, with an option of either curved or flush profile door leaves or fully rebated or low thresholds.



PERFORMANCE OVERVIEW

Security

To ensure your home is protected, the Bi-Fold door incorporates high security locking mechanisms throughout. The door has been designed and tested to comply with security standard PAS24 in accordance with the criteria for Secure by Design. All glazing units are internally beaded.

Thermal Performance

Carroll's Glass Bi-Fold doors offer exceptionally low U values using bespoke polyamide thermal isolators designed to minimise heat transfer across the door profiles. This can be further enhanced with a high insulation (Hi+) option of uniquely designed cellular foams which enclose internal cavities within the profile, further reducing heat loss and providing one of the most thermally efficient systems available.

Achievable whole window u-values	Centre pane u-values	
		1.1w/m2k
System 26Hi Bi-Fold *	1.64w/m2k	1.25w/m2k
System 26Hi+ Bi-Fold *	1.42w/m2k	1.03w/m2k

* Door U values based on 3000 x 2200m three pane Bi-fold using warm edge swiss spacer V bars and fully rebated thresholds. Carroll's Glass can provide tailored U-value calculations using their dedicated estimating software to calculate overall project average door U-values for their full range of systems

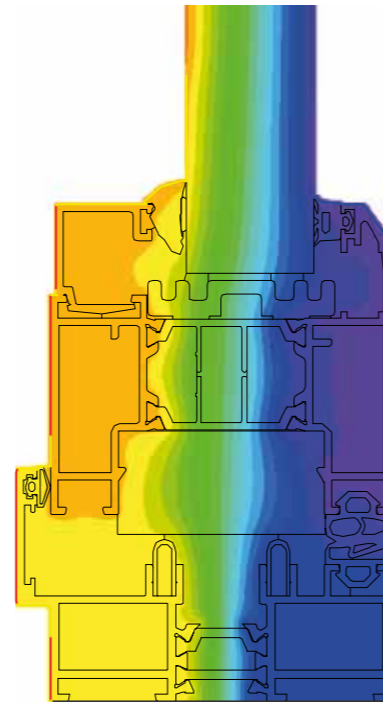

Energy Rating

DSER Rating Scale	Door Rating
↔ A+ ↔	A+
A	
B	
C	
D	
E	
F	
G	

Weather Performance

Air Infiltration BS EN 1026	Class 4
Watertightness BS EN 1027	Class 9A
Wind Resistance BS EN 12211	E1800

Independently Weather Performance Tested to BS 6375-1.

Size Limitations

Door Sash	Door Sash Width	Door Sash Height
Maximum	1100	2500
Minimum	700	1900

BREEAM Sustainability Rating (A+)

Door Energy Rating (A+)

Materials

Aluminum profiles are extruded from aluminium alloy 6060T6, T5 or T4 complying with the recommendations of BS EN 12020-2 / BS EN 755-Parts 1 to 9. Polyamide thermal breaks are produced from glass reinforced nylon sections designed to withstand temperatures in excess of 200°C, allowing the sections to be powder coated after thermal breaking.

Construction

Frame and door sash members are mitre cut at 45°. Corners are reinforced with extruded aluminium crimping cleats and corner braces. A secure joint is formed by pneumatically crimping into the extruded crimping cleat. Mullion and transom bars are square construction against entry of water using our two part adhesive. We recommend that only A2 or cut, shaped and fixed securely to the frame by means of stainless steel screws and fixing cleats. All frame joints are sealed during A4 austenitic (300 series/class 70) stainless steel fixing screws are used in the assembly of their products.

Finishes

The range of sections can be provided in either of the following ranges of finishes:

1. Anodised to BS EN 12373-1 or BS 3987
2. Powder organic coated to BS 6496 or BS EN 12206-1

The system 26Hi/Hi+ Door can accommodate a different colour/finish internally to that used externally.

Glazing

This system offers internally glazed sashes and can accommodate glazing units from 28mm to 50mm units.

26Hi System

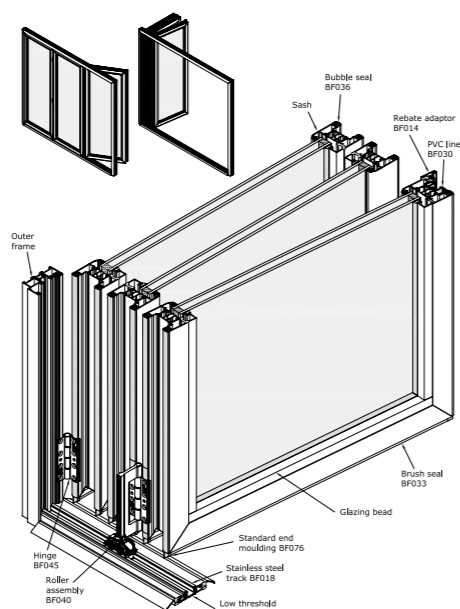

26Hi+ System

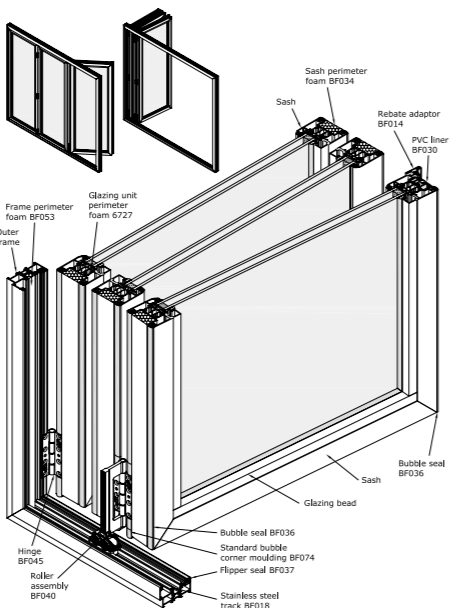

Sill Options

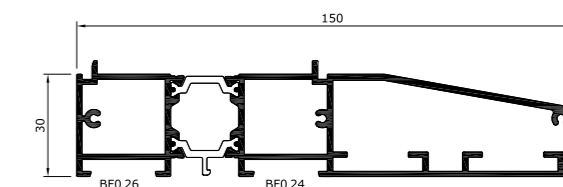

BF02 4026
150mm SUB-CILL
(Not suitable for use with coupling mullions)

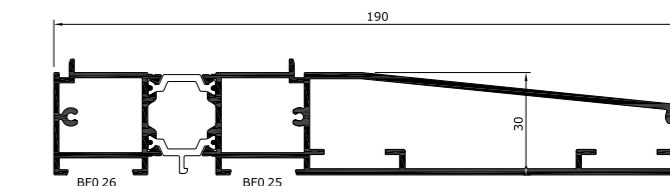

BF02 5026
190mm SUB-CILL
(Not suitable for use with coupling mullions)

Curved Door Sash

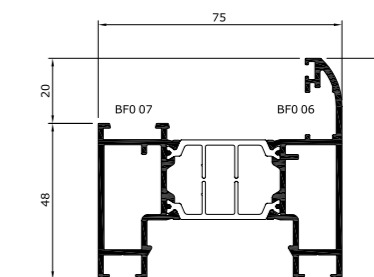

BF00 6007
CURVED DOOR SASH

Outer Frame

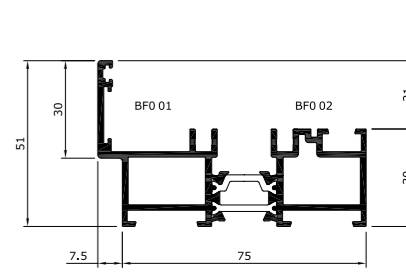

BF00 1002
OUTER FRAME

Low Level Threshold & Ramp

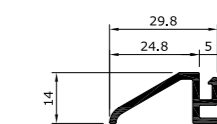

BF0 16
SLIDE ON THRESHOLD RAMP

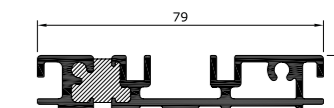

BF0 17
LOW THRESHOLD

Door Configuration Options

PLEASE NOTE: Options 2B (2-2-0), 4B (4-4-0) & 6B (6-6-0) have no external handle or access.

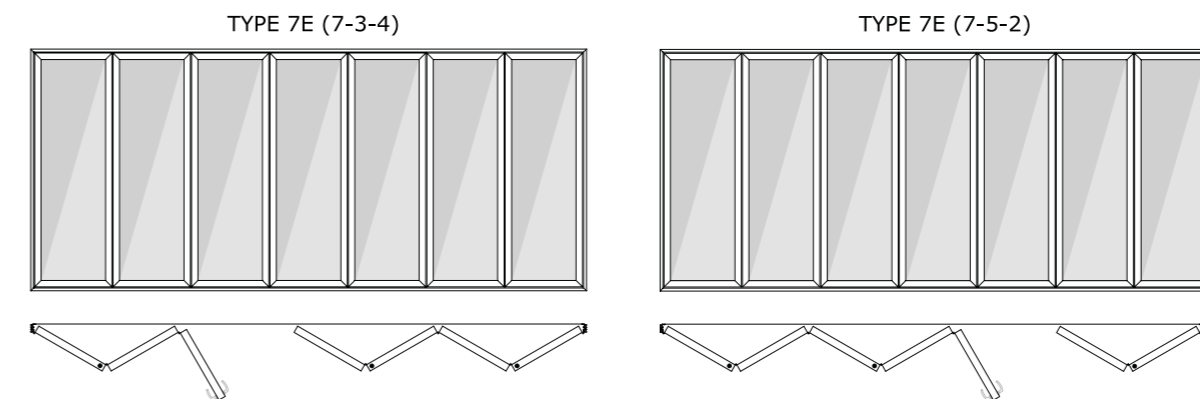
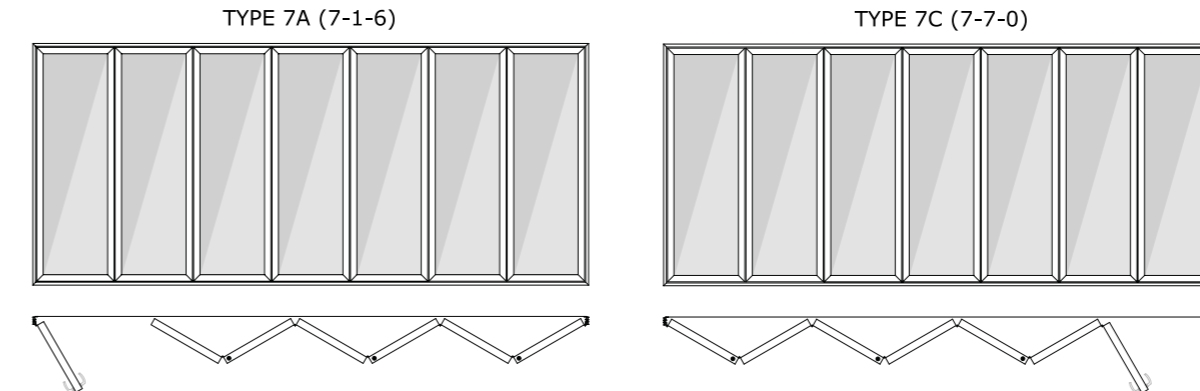
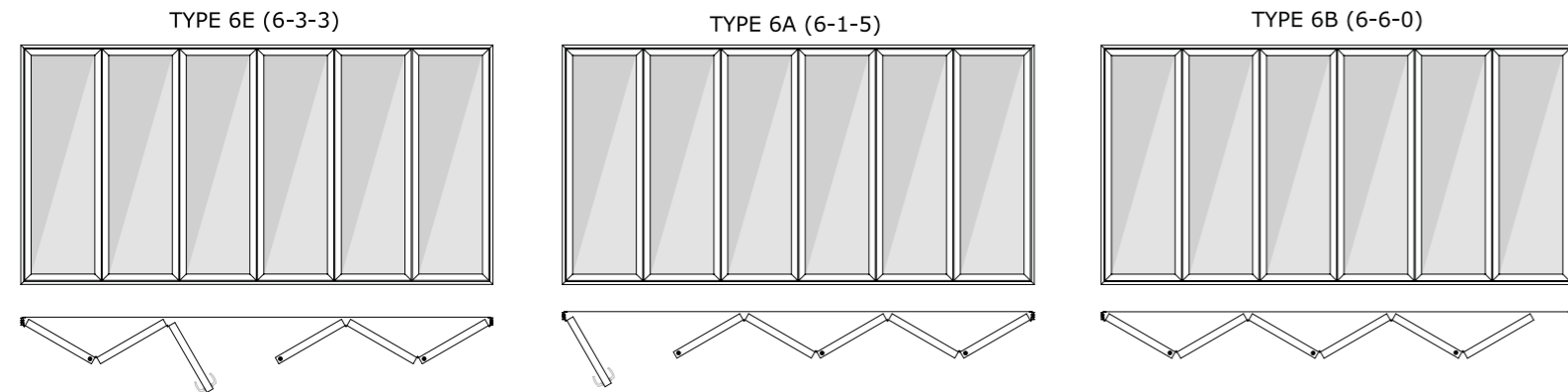
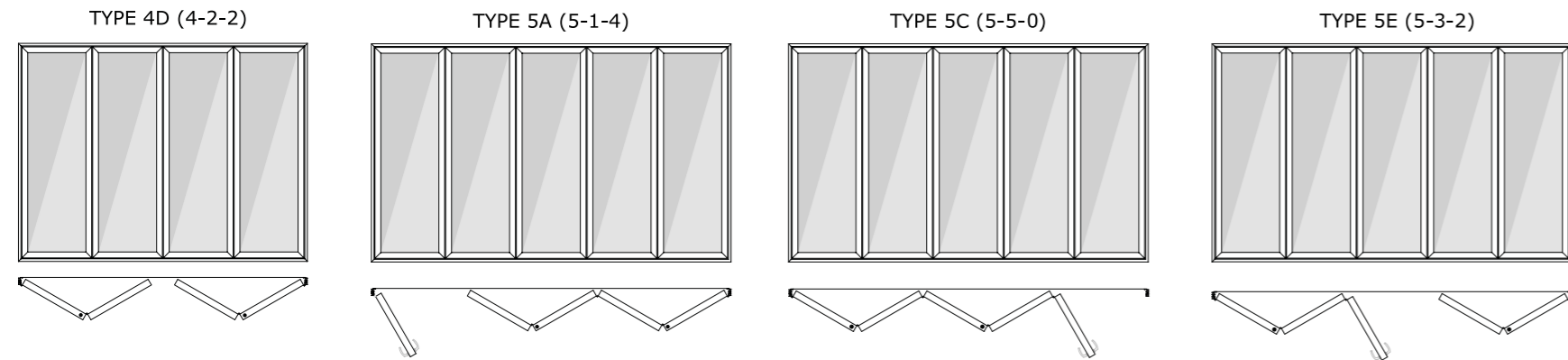
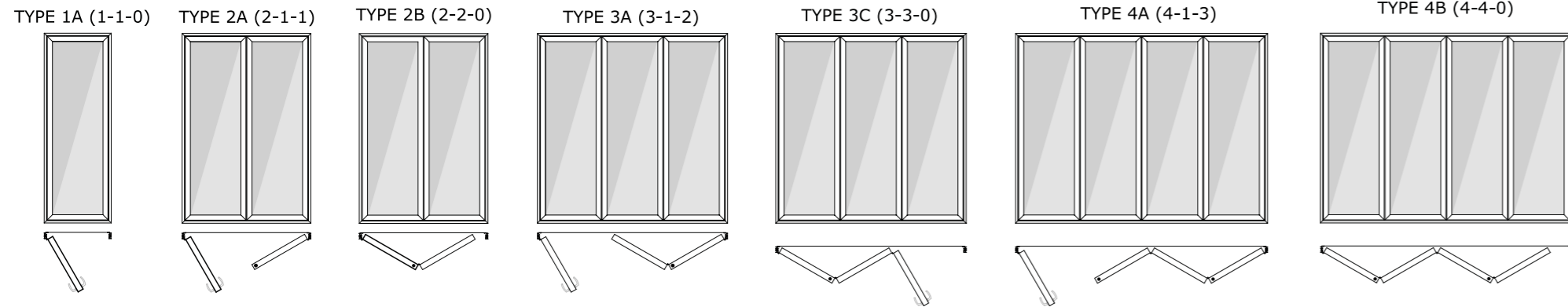

D - Pull Handle



Standard Shoot-bolt Handle



Shoot-bolt Handle with Euro Lock



Colours

7016*	Anthracite Grey - Matt Finish
9005*	Black - Satin Finish
9016*	White - Semi Gloss Finish
7016* 9016*	Dual Colour (Anthracite Grey & White)

*Standard colours

Lever Door Handle Colour Options

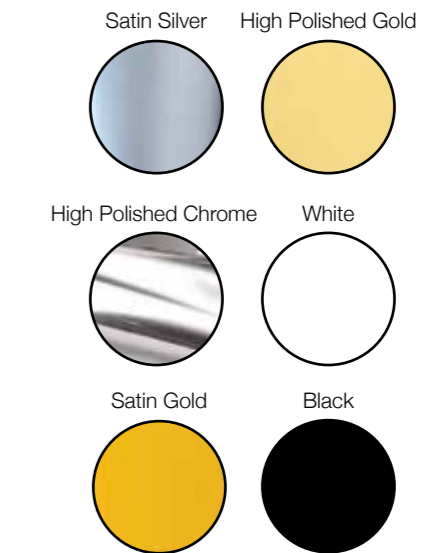

Sliding & Lift and Slide Systems

Confort 125

The C125 is a thermally insulated aluminium sliding and lift-sliding door system that is durable, stable and robust. Available in a 1, 2 and 3 rail version, a 6-leaf door is perfectly feasible.

With a maximum sash weight of 240kg for the sliding and 300kg for the lift-sliding version, large glazed areas are easily attainable.



sapa:

A combination of strong aluminium profiles and stainless steel rollers with polyamide support allow C125 to be used for glazed areas up to 2.7m (height) for the sliding version. These stainless steel rollers are self-levelling which assures that the sash glides effortlessly up to the maximum weight of 240kg in Sliding, whilst the lift-slide hardware allows sashes up to 300kg with glazed areas up to 2.8m.

Design

- » The gutter section frame allows the internal floor finishes to be flush with the inner frame and avoids thresholds.
- » All standard shades and ventilation systems can easily be integrated.

Confort 125 is available in 1-, 2-, 3-rail, each offering specific advantages and design solutions:

- » Confort 125, 1-rail: Combination of a sliding sash and a fixed screen, which can also include turning sashes. Fixed screens can be integrated on top or at the sides of the sliding sash by using an integrated combination profile.
- » Confort 125, 2-rail: Combination of sliding sashes with 1, 2, 3 or 4 sashes; fixed and sliding parts have the same sightline.
- » Confort 125, 3-rail: Combination of sliding sashes with 3-rail frame, max. 6 sashes. The perfect solution for larger glass surfaces.



Resistance

- » Efficient water evacuation is ensured via punched drain holes and integrated sealing plugs.
- » Hi-Fin brush gaskets ensure perfect weather resistance in the sliding version.
- » For the lift-slide version, EPDM gaskets guarantee perfect tightness.
- » Brush draught excluders, positioned centrally between each sash, keep the sliding doors draught free.
- » The glass fibre reinforced polyamide strips (PA 6.6 GF25) ensure good thermal insulation. The synthetic protection gutter offers an increased thermal protection.
- » Weather resistance:
sliding version: 4 (EN 12207); 7A (EN 12208); C4 (EN 12210)
lift-slide version: 4 (EN 12207); 8A (EN 12208); C3 (EN 12210)

Maintenance

- » All Sapa System profiles can be easily cleaned.
- » Aluminium does not rust, rot or tear and the shape does not deform.
- » Aluminium is a green product. It can be recycled infinitely without quality loss.

Security

- » Multipoint security locks to all sliding and lift-sliding versions as standard.
- » The lock of the sash has an anti-lift device. Moreover, a central security piece on top of the sash prevents lifting.
- » Internal tubular glazing beads prevent unclipping of the glazing beads from the outside.
- » The lock of Confort 125 can include a night sash position, which assures a healthy ventilation of the building.
- » Security level: ENV 1627 - 1630 class 2



Finishes

- » Over 400 powder coated paint colours in matt, gloss or satin.
- » Textured and textured metallic ranges are available.
- » Anodised finish is also an option.
- » Accessories can be supplied in corresponding colours to match the profiles.
- » Polyamide thermal breaks allow bi-colour finishes, so that the exterior design requirements do not infringe the interior design requests.
- » Our surface finishes meet the highest standards of Qualicoat or Qualanod.

Handle Options and Colour Options

Standard D



Lift and Slide



Finger Dish*



Stainless Steel D*



Satin Silver

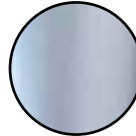

High Polished Gold

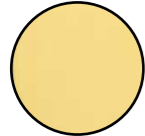

Satin Gold



Satin Silver

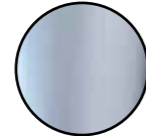

Stainless Steel

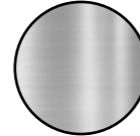

High Polished Chrome



White

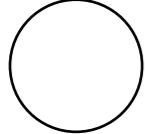

Black

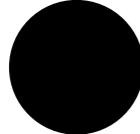

Colours

7016*

Anthracite Grey - Matt Finish

9005*

Black - Satin Finish

9016*

White - Semi Gloss Finish

*Standard colours

Door Options

Slide

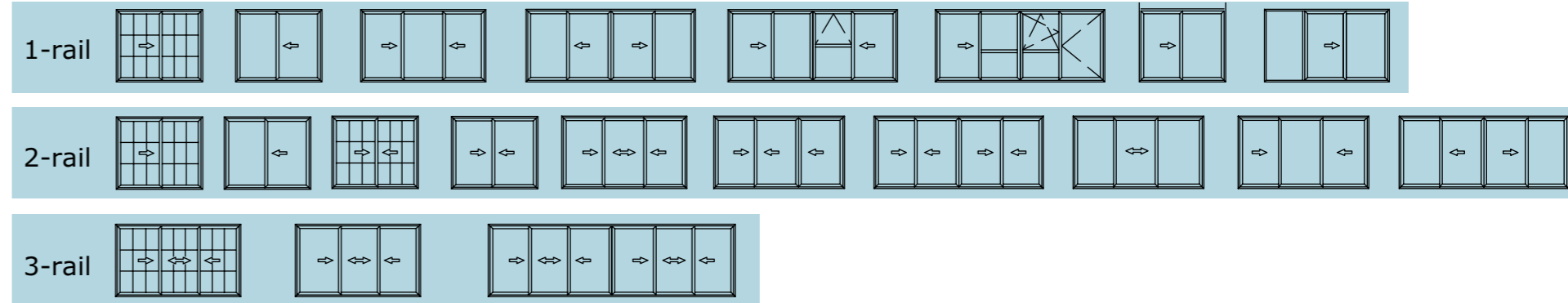

Lift-Slide

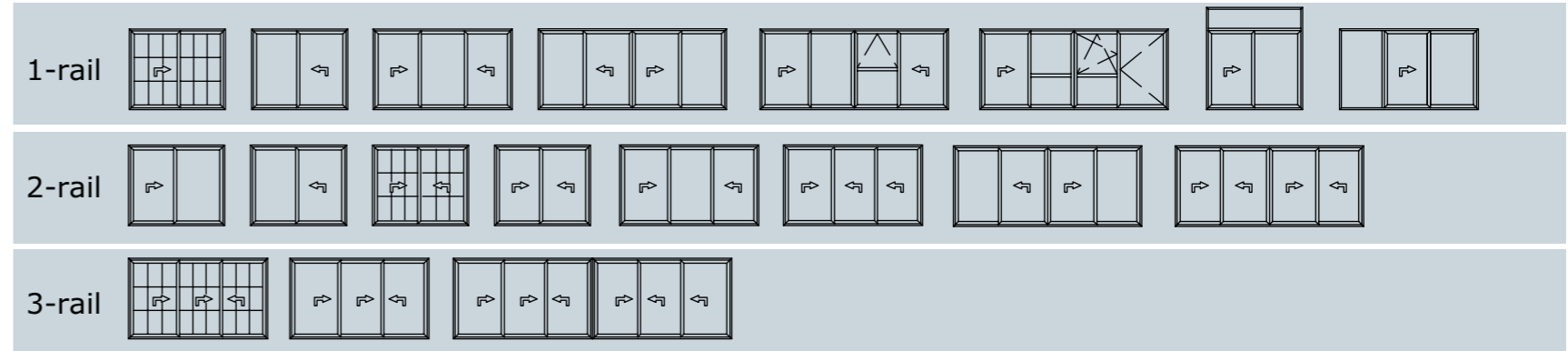

*Satin silver thumbturn lock cylinder can only be used with these options.





Mono Rail

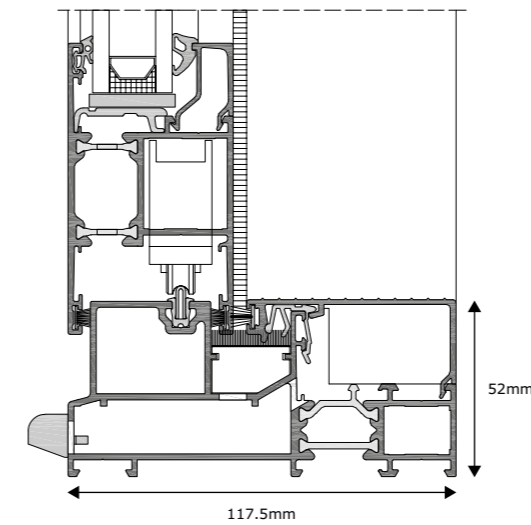

Dual Rail

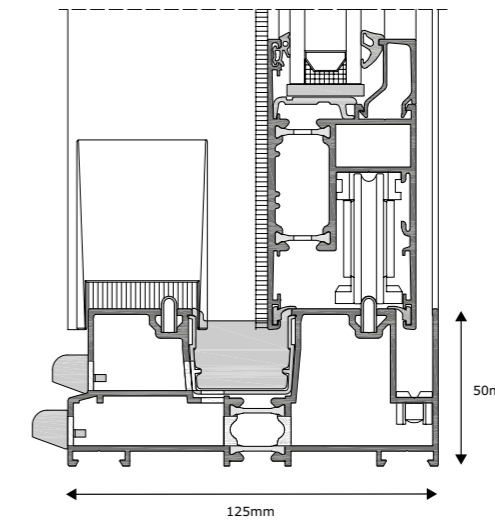

Triple Rail

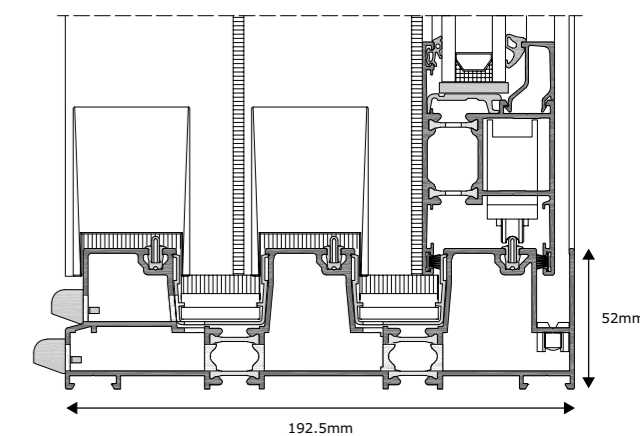

Dimensions

Min. sightline 1-rail (fixed part)	50 mm
Min. sightline 1-rail (sliding part)	131 mm
Min. sightline 2-rail and 3-rail (sliding part)	131 mm
Min. sightline of interlocker	92 mm
Profile depth 1-rail	117,5 mm
Profile depth 2-rail	125 mm
Profile depth 3-rail	192,5 mm
Profile depth sash	50 mm

Glazing

Infill thickness fixed parts 1-rail	4 - 38 mm
Infill thickness sliding parts 1-, 2-, 3-rail	4 - 38 mm
Glazing method	dry glazed with EPDM gaskets or silicon

Registered Installer

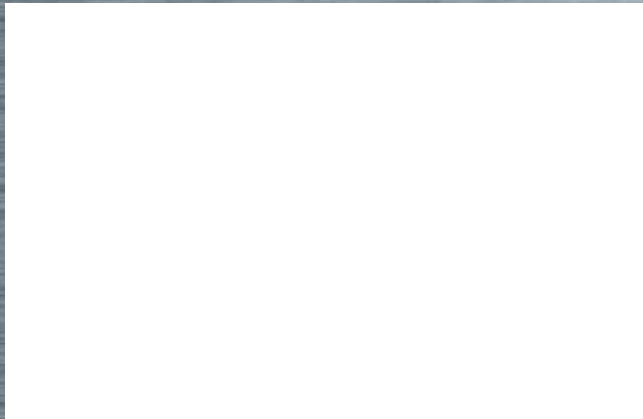

6 Ballyoran Lane, Castlereagh,
Belfast BT16 1XJ

Tel: 028 90481116

Fax: 028 90483576

E-mail: info@carrollsglass.co.uk

Web: www.carrollsglass.co.uk

Why aluminium?

Frame strength is very important when deciding on which window system to choose.

Aluminium is strong, durable and aesthetically pleasing and this is why it is Carroll's material of choice.

Aluminium not only combines strength and robustness with a lightweight structure, which means the frame won't twist or warp, not forgetting its thermal performance break technology.

